

**MRS-6
Maxi-Guard II**

**Model:
C86006-11, 12, 13, 14**

OPERATION

SERVICE

PARTS

CARE



Revised 6/02

Minuteman[®]

OPERATING INSTRUCTIONS

INSPECTION

Carefully unpack and inspect your machine for shipping damage. Each unit is tested and thoroughly inspected before shipment and any damage is the responsibility of the delivering carrier who should be notified immediately. Read all instructions carefully before operating.

WARNING

Electrical shock could occur if used on wet surfaces. Do not expose to rain. Store indoors.

Electrical motors can cause explosions when operated near explosive materials or vapors. Do not operate this machine near flammable materials such as solvents, thinners, fuels, grain dust, etc.

CAUTION

Hazardous materials must be disposed of properly. Never throw contaminated debris in your usual trash receptacle. Place debris in a plastic bag or can marked "HAZARDOUS MATERIALS" and take to a hazardous waste handler.

ELECTRICAL - 115 Volt

This machine is designed to operate on a standard 15 amp, 115 volt, 60 hz, AC circuit. Voltages below 105 AC or above 125 volts AC could cause serious damage to the motor.

ELECTRICAL - 240 Volt

This machine is designed to operate on a standard 10 amp, 230 volt, 50 hz, AC circuit.

GROUNDING INSTRUCTIONS

To protect the operator from electrical shock, this machine must be grounded while in use. This machine is equipped with an approved three-conductor cord and grounding type plug to fit the proper grounding type receptacle. This machine is for use on a nominal 120 volt circuit and has a grounding plug that looks like the plug illustrated in sketch A. Make sure that the machine is connected to an outlet having the same configuration as the plug. No adapter should be used with this machine. For equipment rated 150-250 volts: If the machine is provided with an attachment plug as shown in sketch B, it is intended for use on a 240 volt (nominal) circuit. No adapter is available for this plug.

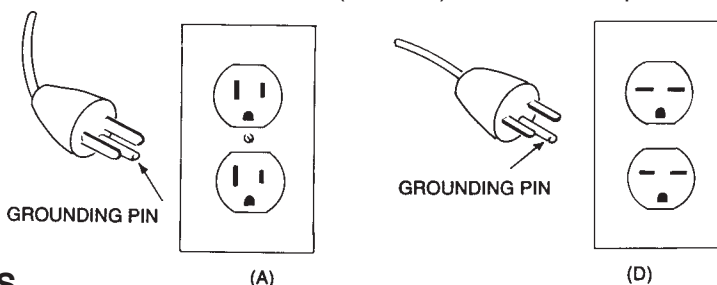

EXTENSION CORDS

If an extension cord is used, the wire size must be at least one size larger than the power cord on the machine and must be limited to 25 feet in length. Extension cord must be three-wire grounded.

MAINTENANCE AND USAGE

Keep the motor intake cooling air screen clean. If this screen (on top of the motor) becomes clogged, it restricts the flow of cooling air to the motor and will cause overheating. No lubrication of the motor is required. Machine is equipped with sealed bearings. For optimum performance, empty and clean filter bag regularly. A clogged and dirty bag restricts the flow of air and results in reduced vacuum. Check carbon brush periodically. Replace when worn down to approximately 1/2" in length. Always unplug the machine when removing the motor head off the tank. This will prevent the accidental starting of the motor and the possibility of fingers or objects getting into the unprotected impeller intake.

CAUTION

The MRS-6 Mercury Recovery Vacuum has been designed for the recovery of liquid mercury or mercury oxides as a result of spills in small quantities. It should not be used as a conventional vacuum for every day cleaning unless it applies to the recovery of mercury contaminated debris. When not in use, the machine and all of its components should be stored in a cool, dry and well ventilated room. If possible the room should be vented to outside air. Storing area **should not** have air return vent leading to air circulating central system. Always wear the required and proper face mask, gloves and protective clothing when cleaning up a mercury spill. Check with your Safety Department or your work supervisor if you are not familiar with the use and procedure for operating a mercury recovery vacuum.

OPERATING AND FILTER CARE INSTRUCTIONS (refer to schematic on page 4)

1. Tank assembly is equipped with low intake on outside and 2" tube inside.
2. Carefully open the folds of the disposable collector bag No. 3 and insert into tank.
3. Place the cardboard collar onto the intake tube and carefully pull the collar over the tube until the rubber gasket is past the ring on the end of the tube.
4. Place the charcoal filter holder assembly No. 2 onto the rim of the tank making sure that the gasket seats fully around the tank.
5. Place the motor lid assembly No. 1 onto tank, making sure it is seated.
6. Snap on lid latches from tank to vacuum lid.
7. Install hose assembly onto tank intake.
8. Attach vacuum tools to be used.
9. Plug electric cord into wall receptacle and turn on vacuum.
10. With vacuum on, spray anti-static spray (PN 920372) into end of pickup tool. This will coat the tool and hose to reduce static electricity.
11. Your MRS-6 is now ready for use.

PROCEDURE FOR CLEANING MRS-6 AFTER USE

1. Remove hose and insert plugs provided at each end.
2. Place hose and tools used into plastic bag and seal with ties.
3. Unplug electric cord and remove vacuum lid from tank assembly.
4. Remove charcoal filter assembly from tank.
5. Reach into tank and gently push the collar of the filter bag off the tube, seal bag opening with adhesive backed "Mercury Caution Decal" provided, and carefully remove collector bag from tank.
6. Place collector bag into plastic bags provided.
7. Use dampened disposable wiper towels or cloth to wipe down inside of tank assembly. Place wipers in plastic bag for disposal.
8. Inside of tank should be checked with "sniffer" or comparable air measuring device to determine if all traces of mercury have been removed. Any mercury residue left in the tank assembly may result in rapid deterioration of the charcoal filter.
9. Reassemble vacuum following directions on Page 4. With vacuum assembled and all filters in place, plug in electric cord and turn vacuum on. Take a sniffer reading of the air exhausted around the motor lid assembly to determine if charcoal filter requires replacing. The highest safe exposure concentration level is 0.05 mg/M3. Any reading above this level would require a charcoal filter change.
10. Contaminated charcoal filters must be disposed of in the same manner as the collector bag you removed from the vacuum. Check with your Health/Safety Department for proper disposal procedures. (DO NOT HEAT OR BURN ANY MERCURY CONTAMINATED ITEMS.)

OPTIONS (see Page 4)

1. Mercury separator No. 5 with jar No. 6 can be used with MRS-6 for purpose of collecting and separating mercury from debris.
2. Tank stand No. 7 is required to elevate vacuum when mercury separator is used.
3. Wheel bracket assembly No. 750003 for mounting MRS-6 vacuum is available for increased portability. Wheel bracket cannot be used with mercury separator and tank stand.

CHANGING THE CHARCOAL FILTER

1. Place charcoal filter module upside down on table covered with paper.
2. Remove eight retaining screws.
3. Remove holder cover.
4. Remove charcoal filter canister and place in disposable plastic bag.
5. Check sealing gasket, replace if broken.
6. Place new charcoal filter with cover down onto module.
7. Replace cover and screws, fasten screws evenly by using crisscross pattern.
8. Dispose of paper on workbench with charcoal filter canister.

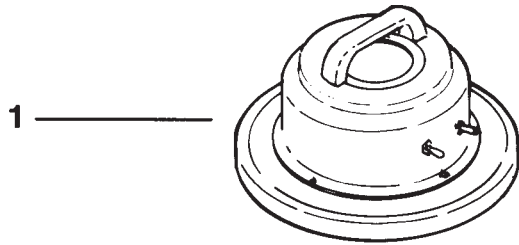

389120 — Lid Assy. 115V
389220 — Lid Assy. 220V

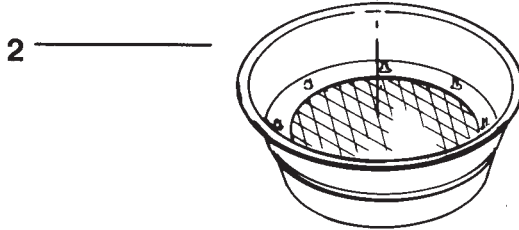

750553 — Mercury Vapor
Canister Assy.

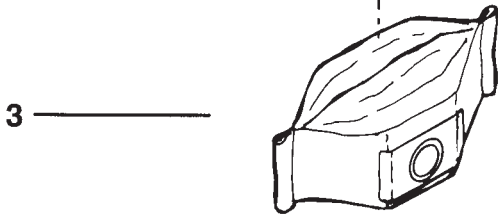

384003PKG — Disposable Paper
Bags, Pkg. of 10

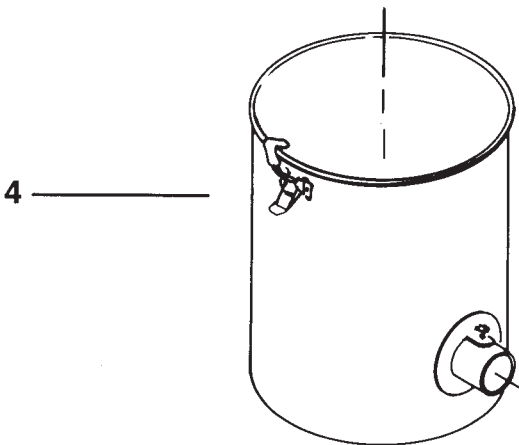

Tank Assy.
See Page 7 Item 10, 10A

7 —
750533 — Tank Stand

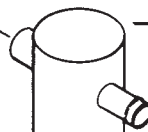
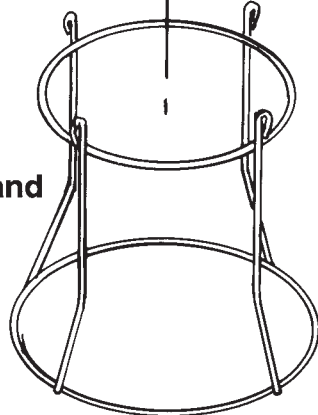

5
750490 — Mercury Separator

750489 — Mercury Separator
Assy. Includes 5, 6



6
761764 — Plastic Jar

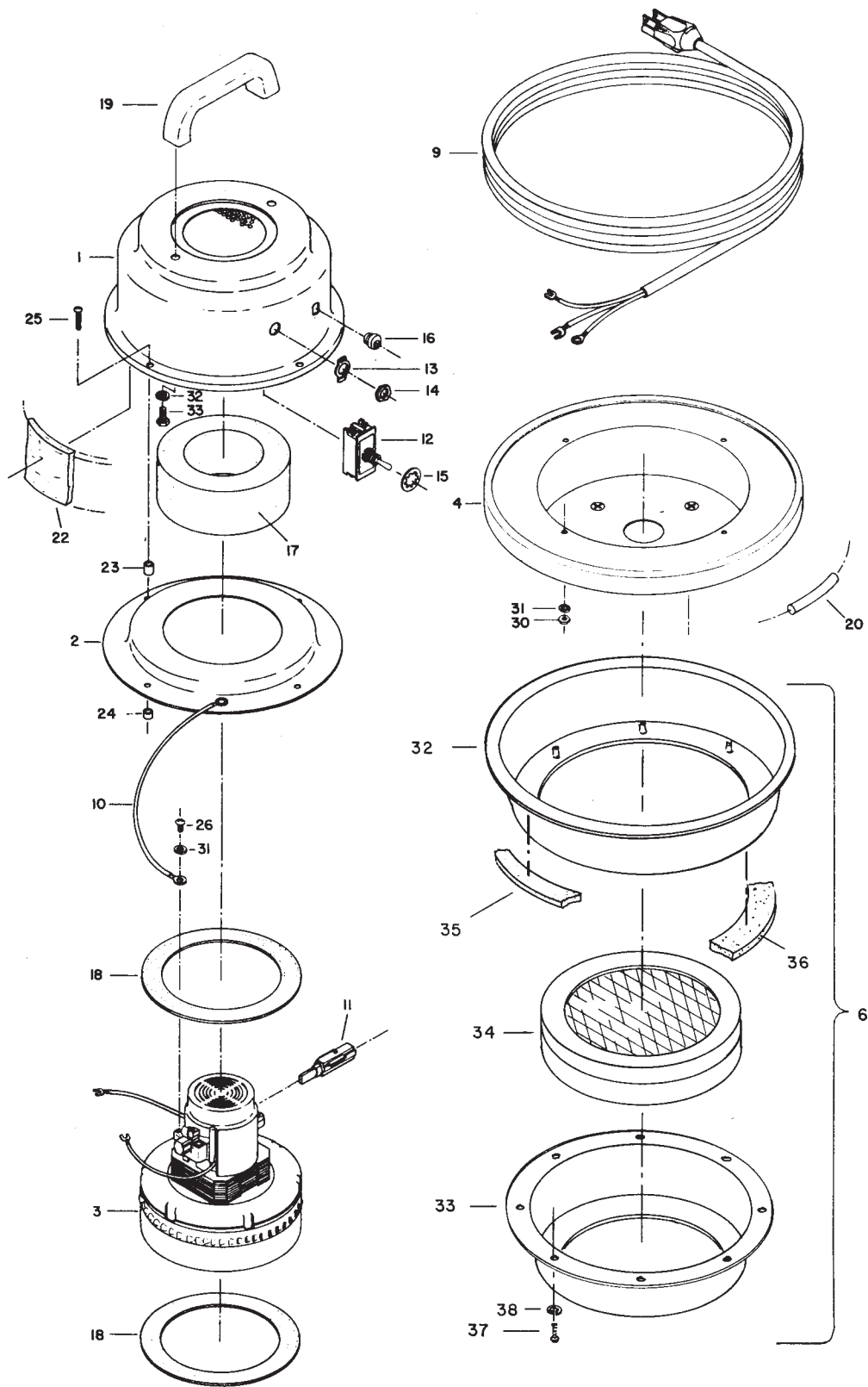

Parts List

Item	Part No	Qty	Description
1	750414	1	Dome Weldment
2	750000	1	Assembly Motor Hold Down
3	380001	1	Motor, 120V
3A	380054	1	Motor, 220V
4A	380063POL	1	Lid Only
4B	750064	1	Lid Assy. SS Includes Item 20
5	110012	1	Plate, Mounting
6	750553	1	Assy. Filter Module, Includes 32, 33, 34, 35, 36, 37, 38
9	381020	1	Cord Set, 16-3, 50'
11	380028	2	Brush, Carbon Replacement
12	380002	1	Switch, Toggle 1.5 HP
13	101020	1	Plate, Off/On Indicator
15	711556	1	1/2 Lock Washer
16	380004	1	Relief, Strain
17	380064	1	Ring, Foam
18	380035	2	Gasket , 4.31 X 5.81 X.19
19	130040POL	1	Handle, Polish
20	380044	1	Lid Gasket Only
21	750006	1	Retainer Impact Assy. Includes Item 8
22	380040	1	Felt, 25 X 2.5 X 25
23	380061	4	Bushing
24	380037	4	Bushing
25	710360	4	SCR-MC 10-32 X 1.00 ST PL
26	710353	1	SCR-MC 10-32 X .37 ST PL
27	710328	8	SCR-MC 8-32 X .37 ST PL
28	711519	4	WSR-Flat 25 X 1.0 X .06
29	711373	4	Nut-Nyloc 1/4-20
30	711310	4	Nut-Hex 10-32 St PI
31	711543	5	WSR-Helical SPR Loc #10
32	750558	1	Filter Holder Includes 35, 36
33	762035PTD	1	Filter Retainer
34	750555	1	Mercury Vapor Canister
35	805042	1	Gasket
36	762141	1	Gasket
37	710357	1	SCR-MC 10-32 X .75
38	711543	1	WSR-Lock #10
***	389120	1	Lid Assy. Complete 115V
***	389220	1	Lid Assy. Complete 220V

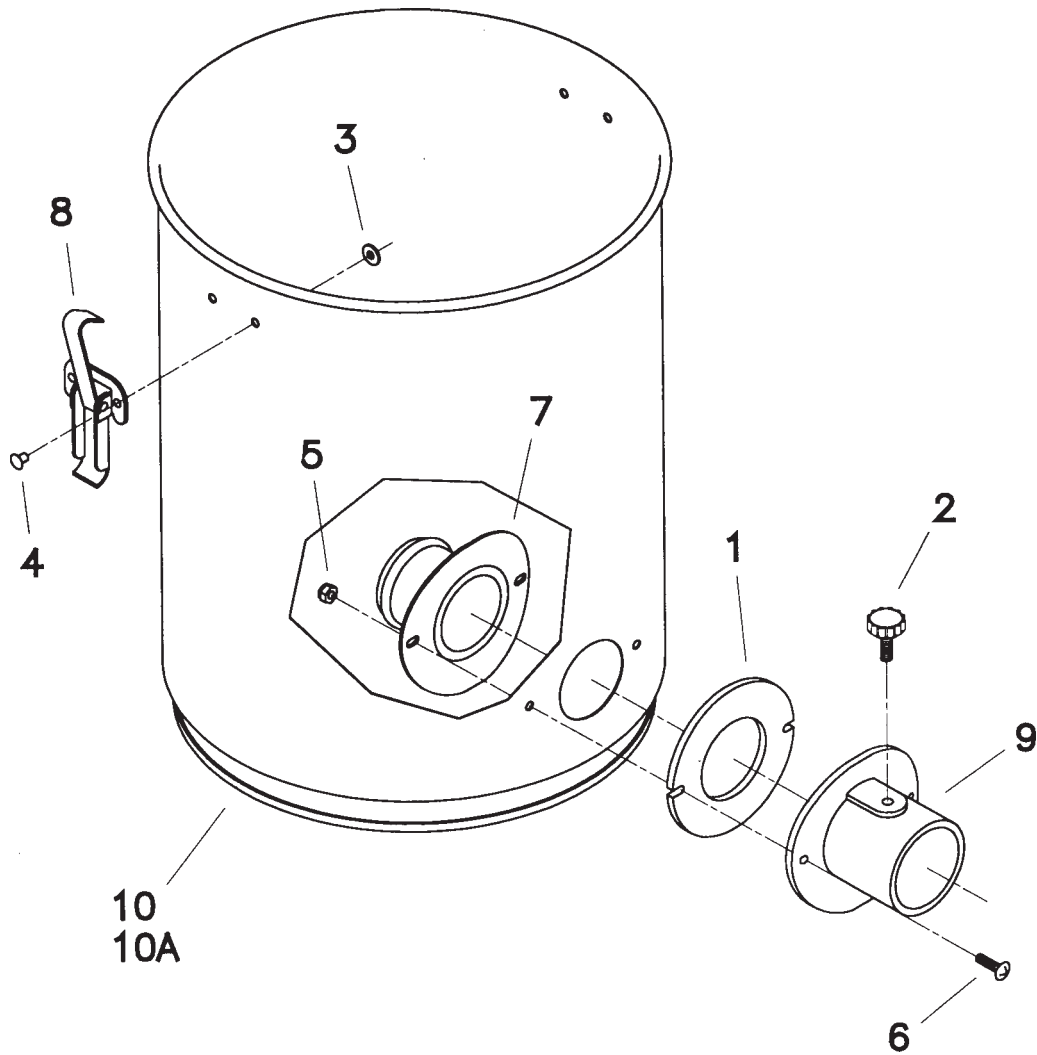

Parts List

Item	Part No	Qty	Description
1	390087	1	Gasket
2	500033	1	Knob
3	711503	4	Washer - Flat #10
4	711915	4	Rivet .19 X .28 X .37 HD STNI
5	712638	2	Nut-Hex 10-24 SS Nyloc
6	712824	2	SCR-THMS 10-24 X .75 SS
7	750118	1	Intake Tube Assembly
8	761054	2	Latch
9	900039	1	Intake
10	900093	1	Tank, 6 Gal. SS Low Intake
10A	900092	1	Tank, 6 Gal. PTD Low Intake
***	384003PKG	1	Disposable Paper Bag (10)
***	761177PKG	1	Paper Filter Protector (12)
***	380049PLT	1	Bag Frame

LIMITED WARRANTY

Minuteman International, Inc. warrants to the original purchaser/user that this product is free from defects in workmanship and materials under normal use and service for a period of three years from date of purchase. In addition, Minuteman International, Inc. will, at its option, honor labor warranty claims for the first 12 months from date of sale, provided such claims are submitted through and approved by factory authorized repair stations. Minuteman International, Inc. will, at its option, repair or replace without charge, except for transportation costs, parts that fail under normal use and service when operated and maintained in accordance with the applicable operation and instruction manuals.

This warranty does not apply to normal wear, or to items whose life is dependent on their use and care, such as belts, cords, switches, hoses, rubber parts, electrical motor components or adjustments. Parts not manufactured by Minuteman International, Inc. such as engines, batteries, battery chargers, hydraulic pumps, and tires are covered by and subject to the warranties and/or guarantees of their manufacturers. Please contact Minuteman International, Inc. for procedures in warranty claims against these manufacturers.

Special warning to purchaser — Use of replacement filters and/or prefilters not manufactured by Minuteman International, Inc. or its designated licensees, will void all warranties expressed or implied.

A potential health hazard exists without exact original equipment replacement.

All warranted items become the sole property of Minuteman International, Inc. or its original manufacturer, whichever the case may be.

Minuteman International, Inc. disclaims any implied warranty, including the warranty of merchantability and the warranty of fitness for a particular purpose. Minuteman International, Inc. assumes no responsibility for any special, incidental or consequential damages.

This limited warranty is applicable only in the U.S.A. and Canada, and is extended only to the original user/purchaser of this product. Customers outside the U.S.A. and Canada should contact their local distributor for export warranty policies. Minuteman International, Inc. is not responsible for costs or repairs performed by persons other than those specifically authorized by Minuteman International, Inc. This warranty does not apply to damage from transportation, alterations by unauthorized persons, misuse or abuse of the equipment, use of non-compatible chemicals, or damage to property, or loss of income due to malfunctions of the product.

If a difficulty develops with this machine, you should contact the dealer from whom it was purchased.

This warranty gives you specific legal rights, and you may have other rights which vary from state to state. Some states do not allow the exclusion or limitation of special, incidental or consequential damages, or limitations on how long an implied warranty lasts, so the above exclusions and limitations may not apply to you.

Minuteman[®]

World Headquarters
Minuteman International, Inc.
111 South Rohlwing Road
Addison, Illinois 60101

Minuteman Canada, Inc.
2210 Drew Road
Mississauga, Ontario
L5S 1B1

(630) 627-6900
FAX (630) 627-1130

(905) 673-3222
FAX (905) 673-5161

987844
Printed in U.S.A.